

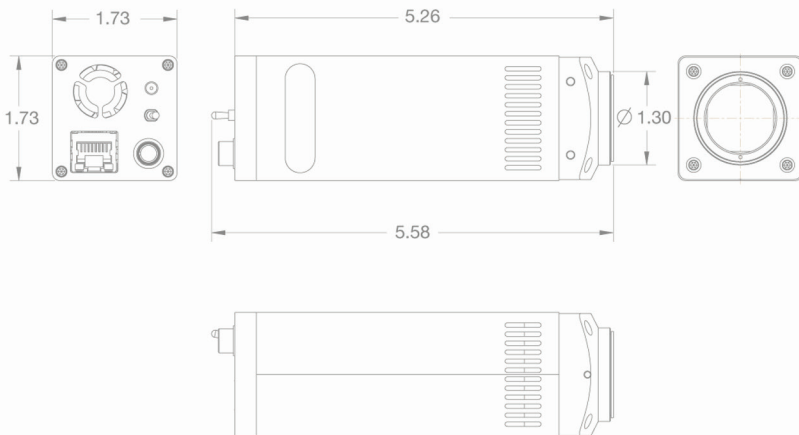

InsightTM GIGABIT | 4.0 MP Monochrome

The SPOTTM Insight Gigabit delivers high speed imaging at 4.0 megapixel resolution with exceptionally low read noise. By using a large format CCD sensor, the Insight Gigabit captures a wide field of view and eliminates the need for expensive de-magnifying optics. Its small package size and extended cable length options offer flexible configuration options. The suggested applications for this camera include widefield monochrome imaging, high speed acquisition, bright fluorescence, slide scanning, inspection, and phase contrast studies.

The SPOT Insight Gigabit comes with the easy to use SPOT Basic software which is fully compatible with both Windows[®] and Mac[®] operating systems, and features real time image previewing, acquisition, scale bar addition, report generation, time lapse, and measuring capabilities. A well-documented, free SDK and extensive third party driver support make integration with existing applications easy. Advanced triggering enables precise synchronization with peripherals.



Features	Benefits
Large Size CCD (21.4mm diagonal)	When used with a 1X (no lens) microscope adapter, the large CCD creates images that closely match the view through the eyepieces
High Resolution CCD (2048 x 2048 4.0 Mp)	The high-resolution 4.0 Mp CCD allows you to capture a large area of the specimen with each image, requiring fewer stage movements to acquire a full slide
Fast Frame Rate (14 fps at 4 Mp) and Real Time HDTV viewing	Real time high resolution preview capture and high speed scanning
18 e ⁻ Read Noise	Remarkably low read noise for a camera of this speed, provides great sensitivity for low-light imaging
Mac [®] and Windows [®] OS Support	All SPOT application software runs in both the Mac [®] and Windows [®] environments



Sensor	
Resolution	4.0 Mp
Sensor Type	Kodak KAI-04022M Progressive Scan Interline CCD (monochrome)
Shutter	Electronic global shutter
Active Pixels	2048 x 2048
Pixel Size	7.4µm x 7.4µm
Active Imager Size	15.15 mm x 15.15 mm 21.43 mm diagonal
Exposure Time	200µs – 30 min
Binning	2x2, 3x3, 4x4 and 8x8
Region of Interest	User selectable from 50x50 to full resolution
Read Noise	17-18 e ⁻ rms
Dark Current	0.11 e/p/s
Full Well Depth	19,500 e ⁻
Non-linearity	<1%
Bit Depth	12-bit
Sensor Readout Frequency	Dual Channel 40 MHz
Analog Gain	1, 2, 4, 8, 16 and 32

Camera	
Lens Mount	C-mount
Computer Interface	Gigabit Ethernet
Trigger Connectors (optically coupled)	External trigger input (TTL) External trigger ready output (TTL) Exposure sync output (TTL)
Mounting Holes	Four M3 x 0.5mm tapped holes
Weight	9.7 oz (275g)
Size	1.73" x 1.73" x 5.26" (44 mm x 44 mm x 134 mm)
Power Requirements	100-240 VAC, 50/60Hz
Power Consumption	9 watts max, 7 watts average
Operating Environment	0 to 50°C, 95% relative humidity (non-condensing)
Storage Temperature	-20 to 60°C
Certifications	CE, FCC Class A, EN60950, RoHS

Quantum Efficiency

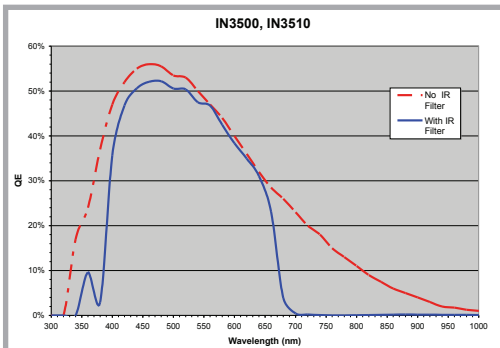

40 MHz Gigabit Frame Rates

Captured Frames per Second *					
Binning level	Live Mode & Sequential Capture (2 channel, 8-bit) frames/sec				
Region of Interest	2048 x 2048	1024 x 1024	512 x 512	256 x 256	50 x 50
No binning	13.8*	23.6	35.7	47.7	65.6
2 x 2	21.7	34.3	48.3	60.6	76.4
3 x 3	24.6	36.4	48.1	57.2	67.3
4 x 4	29.2	42.8	55.6	65.6	76.6
8 x 8	34.8	47.8	59.1	66.7	74.8
Binning level	Sequential Capture (1 channel, 12-bit) frames/sec				
No binning	8.0	14.5	24.0	37.2	64.3
2 x 2	13.6	23.3	36.3	50.4	73.3
3 x 3	17.4	28.4	41.5	53.9	71.0
4 x 4	20.9	33.2	47.2	59.5	75.8
8 x 8	28.4	41.8	54.4	64.9	75.7

*13.8 frames/sec 8-bit, 10.8 frames/sec 12-bit.
Frame rates measured with 1ms exposure time on 2GHz Intel Core 2 Duo T7500 @ 2.2 GHz; 2.00 GB RAM. OS: Windows XP SP2. Post-processing was deferred on sequential images. Frame rates may vary on other processors and operating systems.

SPOT Software	
SPOT Basic Software Features	Live mode viewing window with controls Image capture window Image capture setups are user defined, named and saved Auto or manual exposure for Live and captured images Zoom control on Live and captured images Auto white balance Spot or average metering Flatfield correction Annotation Calibration mark Measurement tools Image enhancement tools Sequential image capture and playback Report generator Interactive print dialog Help menu 3rd Party Software Interface: Twain for Windows®, SPOT Image Capture Application & AppleEvent for Mac®
Computer Operating System Compatibility	Windows®: XP SP3 (32-bit), Vista (32 or 64-bit), 7 (32 or 64-bit) and 8 (32 or 64-bit) Mac®: OS 10.6 - 10.8
Minimum Computer Requirements	PC: 1GHz Pentium 4 (or equivalent x86 SSE2 processor), 1 GB RAM, one available gigabit Ethernet port Mac®: Intel processor, 1 GB RAM, one available gigabit Ethernet port Mac® and PC video: 24-bit color @ 1024 x 768 resolution
SPOT Advanced Software	Available (includes macro feature, floating taskbars and image archiving database)
SPOT Advanced Software Modules (Optional)	Available (adds image display intensity scaling, peripheral device control and extended depth of focus)
Software Development Kit	Available for Mac® and Windows®
Native Drivers for 3rd Party Software	Available (call or visit our website)

Items Included	
Camera Head	With lens cap
Power Supply	With power cord
Ethernet Cable	6 ft. CAT-6, connects camera to computer
Quick Start Installation Guide	Instructions on how to get up and running quickly
Software CD	Includes SPOT Basic software and User Guide
Warranty	2 years from date of purchase

Catalog Number	C-Mount	F-Mount
Insight Gigabit Mono No IR filter	IN3500	NA
Insight Gigabit Mono With IR filter	IN3510	NA

Specifications are typical and subject to change.



6540 Burroughs Avenue • Sterling Heights • MI • 48314-2133
phone: 586.731.6000 • fax: 586.731.6469 • website: www.spotimaging.com
Data Sheet: Insight Gigabit Mono