



12Mp 4K UltraHD

# The New Standard In 4K Presentations...

SPOT's 4K UltraHD system takes you beyond fixed format 4K video presentations. It combines benchmark image quality, easy presentation tools and lets you present both live and captured images.

## Outstanding Image Quality...

**4K UHD** 3840 x 2160

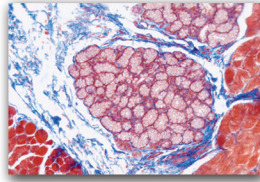

**30+ Frames per Second**

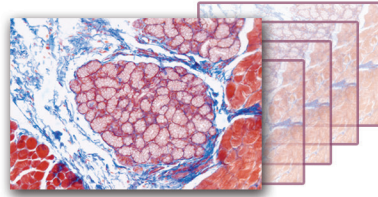

**Live Color Correction**  
With ICC Color Profiles

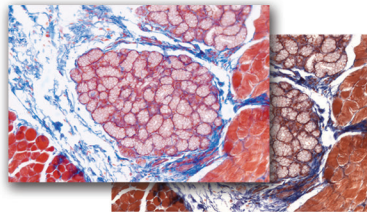

Without ICC Color Profiles

**Benchmark Sensor**

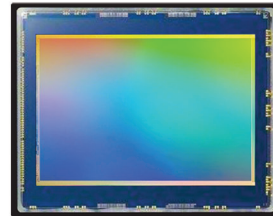

SONY Pregius™

## Easy Presentation Tools Show More and Save Time...

Buying a fixed format 4K UltraHD Video system is like buying an analog phone in the era of Smart Phones, it doesn't make sense. The SPOT 4K UltraHD Video system provides convenient features to enhance your presentation in ways that fixed video system can not. *See the difference...*

### Live and Captured Images

Move fluidly between Live sample presentation and captured image presentation to show related gross imaging, reference support case images and more. Just right click and select.

### Put a Value On It!

Answer attendees questions on distance, area and size. A few clicks sets the calibration and provides the measurement tools.

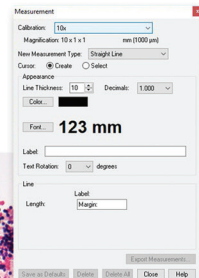

4K FOV

8.2mm<sup>2</sup>  
3.54mm

12.3Mp FOV



### Dual Mode Camera

SPOT 4K UHD can quickly convert to a 12.3Mp format to provide you with that little extra FOV you need on some specimens.

### Use Your Resolution!!

What good is resolution if you can't use it? Simply roll your mouse wheel to zoom in and pan on your image.



See the SPOT 4K UltraHD in action...

Contact Us:  
Email: [www.info@spotimaging.com](mailto:www.info@spotimaging.com)  
Toll Free USA Tel: +1-866-604-SPOT  
Direct Tel: +1-586-731-6000

# SPOT Insight 12.3MP / 4K UHD Camera System

Sensor Specs	
Model	IN42C12IR
Sensor Type	Color Mosaic
Captured Image Resolution	12.3 Mp
Live 4K UHD (8 Mp)	30+ frames per second*
Live 12.3 Mp	29+ frames per second*
Sensor	Sony Pregius™ sCMOS, Back Illuminated
Sensor P/N	Sony IMX253
H x V, Pixels	4096 x 3000
H x V, mm	14.13 mm x 10.35 mm
Pixel Size	3.45 μm
Aspect Ratio	4:3
Sensor Diagonal	17.5 mm
Optical Format	1.1"
Standard Adapter Magnification	1.0x (17.5 mm) FOV
Widefield Adapter Magnification	N/A
Shutter Type	Global Shutter
Peak QE, Color	66% at 525 nm
Fixed Pattern Noise	None
Camera Specs	
Lens Mount	C-mount
Computer Interface	USB 3.0
Full Well	10,300 e
Read Noise	2.4 e
Dynamic Range	73 dB
A-D Bit Depth	12-bit
Analog Gain	1, 2, 4, 8, 16, 32, 64, 128, 251
Exposure Time Range	10 μs to 3.9 sec
ROI	Yes
Exposure While Downloading	Yes
Trigger I/O (OEM models only)	Trigger In* Synch1 Out* I/O/TX, I/O/RX *(Optically isolated, requires external power supply)

Trigger I/O Connector	Hirose HR25-7TR-8A
Power Required	5 V supplied via USB 3.0 Interface
ON-OFF Switch	No
Tripod Mount	Optional
USB Connector	USB 3.0 Micro-B
Regulatory	CE, FCC Class A, RoHS
SPOT Software Application	Windows Mac
SDK Support	Windows Mac Linux

## Color Mosaic + IR Filter QE

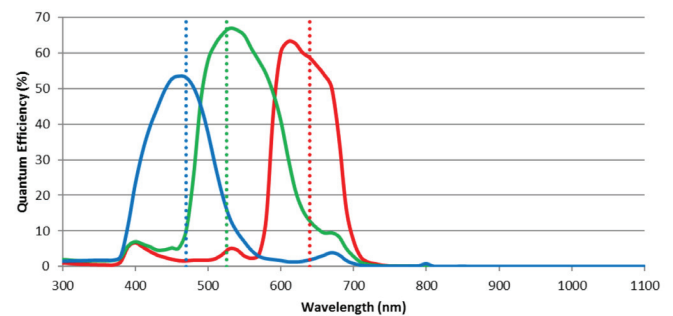

## Dimensions

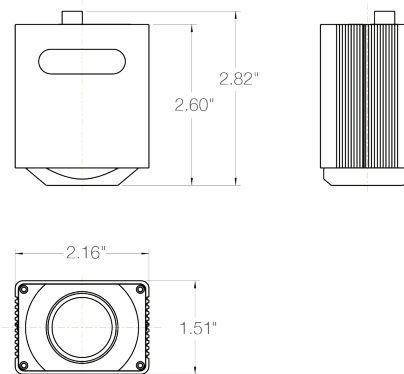

## The suggested applications for this camera include:

- |                           |                                |
|---------------------------|--------------------------------|
| Brightfield               | Histology, Pathology, Cytology |
| Darkfield                 | Semiconductor Inspection       |
| Bright Light Fluorescence | Metrology                      |
| Live Cell Imaging         | Whole Slide Imaging            |

\*Requires computer GPU w/ >400 GFLOPS for these frame rates (Note: These GFLOPS are typical of recent computers)



6540 Burroughs Avenue • Sterling Heights • MI • 48314-2133  
 phone: 586.731.6000 • fax: 586.731.6469 • website: [spotimaging.com](http://spotimaging.com)  
 SPOT INSIGHT sCMOS Camera 4K UltraHD 12Mp